

RENTAL

**h-line**

MODULAR DISPLAYS

20FT+  
DISPLAYS

EDITION TWO 11.11.16

# h-line

## MODULAR DISPLAYS

The **h-line modular display system** addresses the needs of today's exhibitors who are looking for a full visual solution, set-up simplicity that is DIY-esque, and rivals the look of a custom built display. H-line answers these needs through use of the most vibrant dye-sublimation graphics that actually stay attached to the frames while being transported. In addition, it has a unique textile that does not require a blocker panel as well as a specific hardware connection system.

### Key attributes are:

- Full visual solution – no exposed metal
- Simplified I&D – one simple connector
- Graphics are pre-attached to the frames
- Unique textile that does not require a blocker
- One of the most cost effective displays on the market





**SHOWCASE YOUR IMAGE**

Put the graphic image front and center! No visible aluminum profile on backwalls means your message is even more effective and your display becomes an environment.

**ENDLESS MODULARITY**

All module types can be connected to one another -- no restrictions! Rest assured that you can use your booth in every space, even those you have yet to consider. H-line is a completely scalable solution that grows along with your company.

**FOCUS ON THE ESSENTIALS!**

Each module has been designed to provide its own unique functionality (communicate, display, design, spread your message, store, and welcome customers).

**BE CREATIVE!**

Distinguish your company by creating your own custom graphic or use solid colors or patterns.

**CLEVER & SIMPLE**

H-line requires zero technical expertise and is set-up without the use of tools. Set-up the booth yourself, or minimize labor cost. Panels ship with graphics installed. Two people can set-up a 20ft in-line in less than 20 minutes - take down is even faster!



Don't forget to add printed InStep™ carpet!

H-line modular 10ft x 20ft in-lines shown.  
Ask about 10ft x 10ft, 20ft x 20ft Islands or greater options.

# H-line Modular Display



- Vibrant images
- Storage options
- Pre-attached graphics
- Lightbox options
- Accessory attachments



- H-line is a trade show display system which allows you to easily create a custom booth using pre-assembled modules.
- With its full surface area completely dedicated to the graphic image, the H-line creates an unparalleled visual impact while also providing a full assortment of useful functionalities.
- H-line is a perfect solution for those who would like a booth that is both modular and flexible.

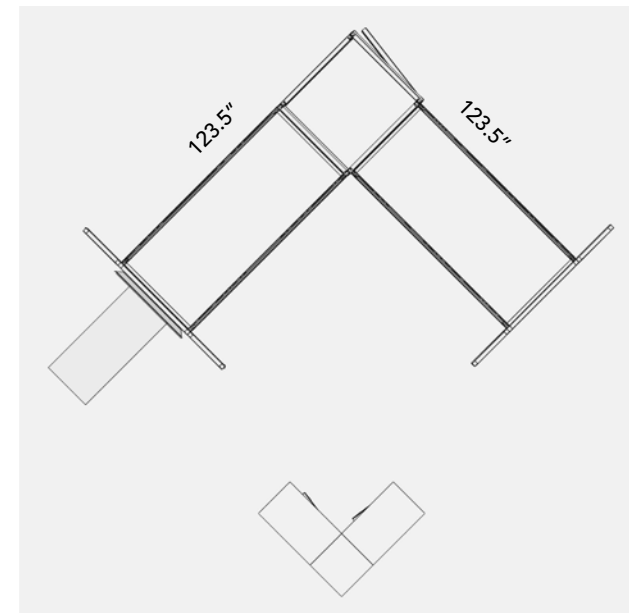
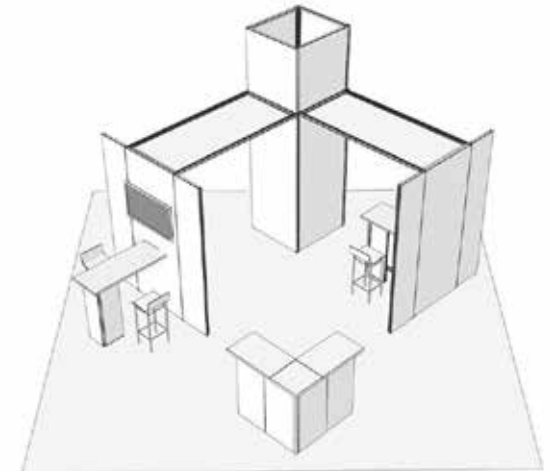

- 123.5" w x 123.5" d x 131" h structure with multi media arch module, storage & graphic

- 1 wood crate (horizontal or vertical available)

**Optional:**

- 27.5" x 39.5" x 17.3" small counters w/door



## H-Line Modular 20ft x 20ft h2020-02

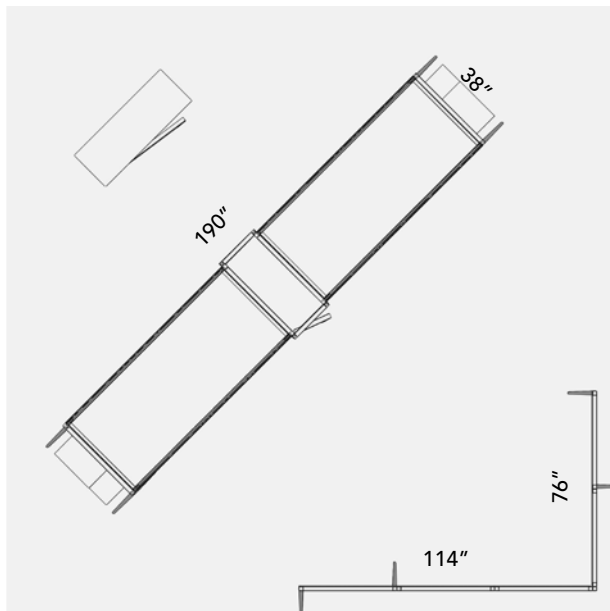
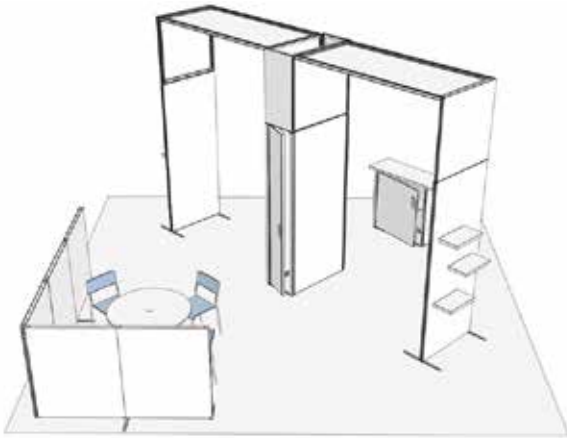

- 190" w x 38" d x 131" h structure with shelf arch module, storage & graphic
- 1 wood crate (horizontal or vertical available)

### Optional:

- 27.5" x 47.25" x 17.3" medium counter w/door
- 114" w x 76" d x 38" h structure & graphic
- Printed InStep™ carpet

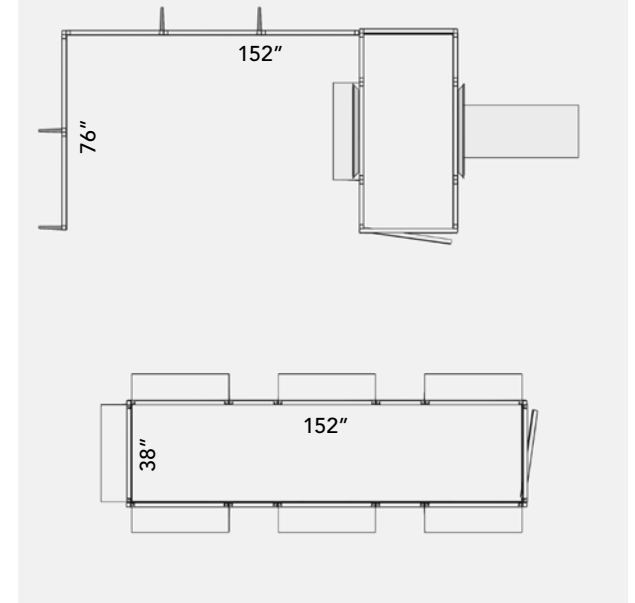
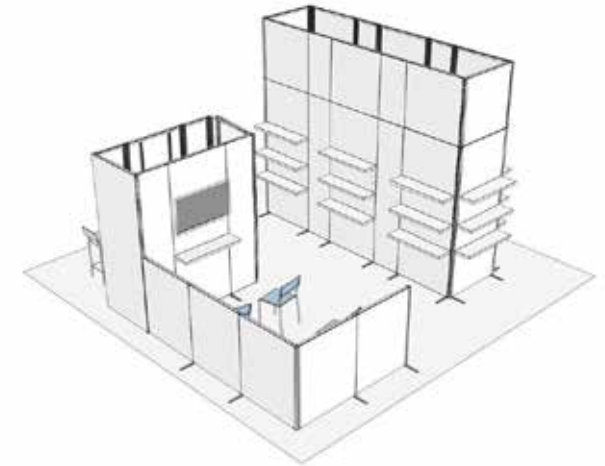

- 152"w x 76"d x 131"h structure with storage & graphic
- 152"w x 38"d x 93"h structure with multi media arch module, storage & graphic
- 1 wood crate (horizontal or vertical available)

## H-Line Modular 20ft x 20ft h2020-04

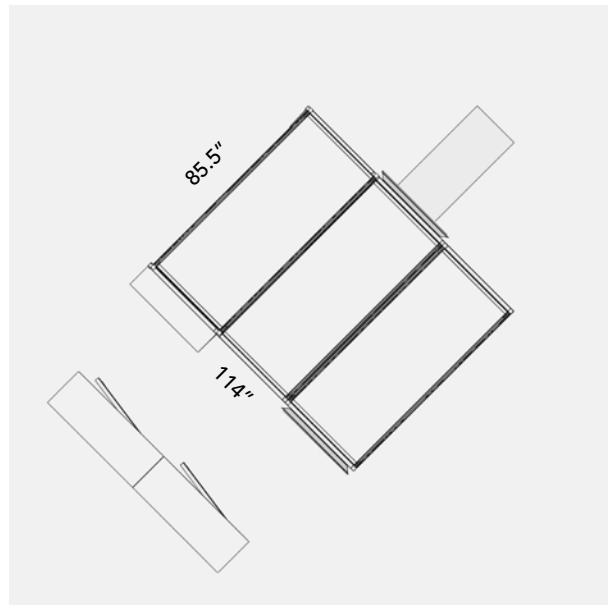
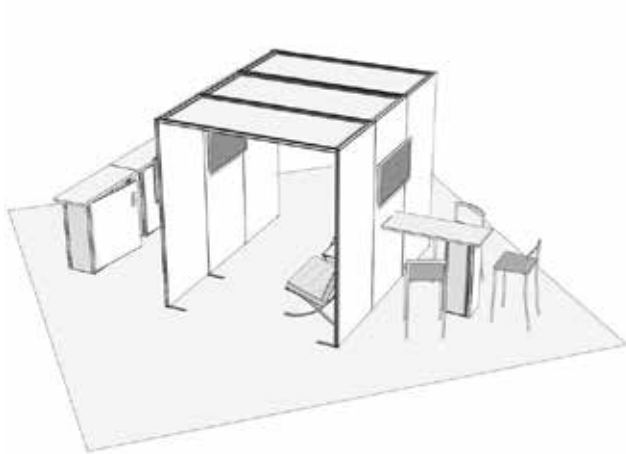

- 114" w x 85.5" d x 93" h structure with multi media arch module & graphic
- 1 wood crate (horizontal or vertical available)

### Optional:

- 27.5" x 47.25" x 17.3" medium counter w/door
- Printed InStep™ carpet



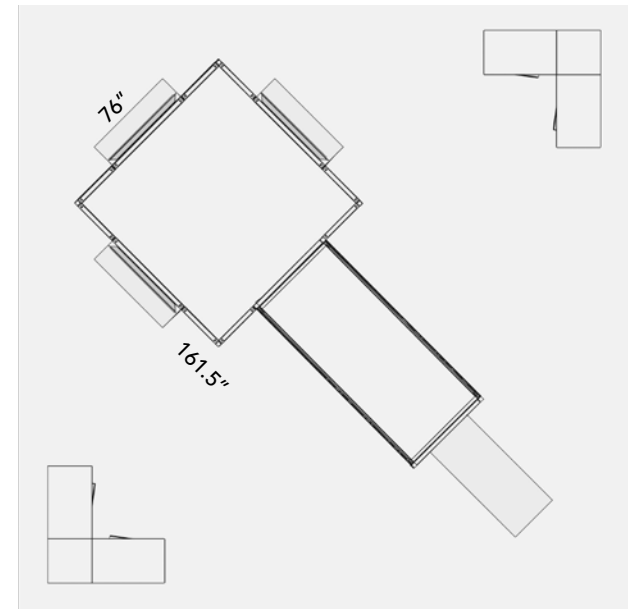
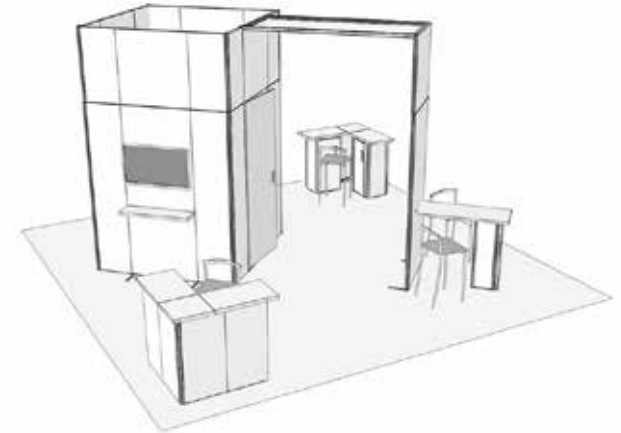

- 76" w x 161.5" d x 131" h structure with multi media arch module, storage & graphic
- 1 wood crate (horizontal or vertical available)

**Optional:**

- 27.5" x 39.5" x 17.3" small counter w/door

## H-Line Modular 20ft x 20ft h2020-06

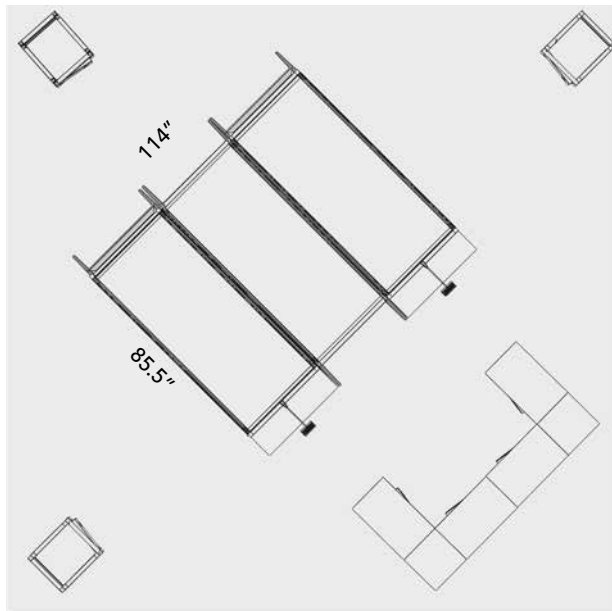
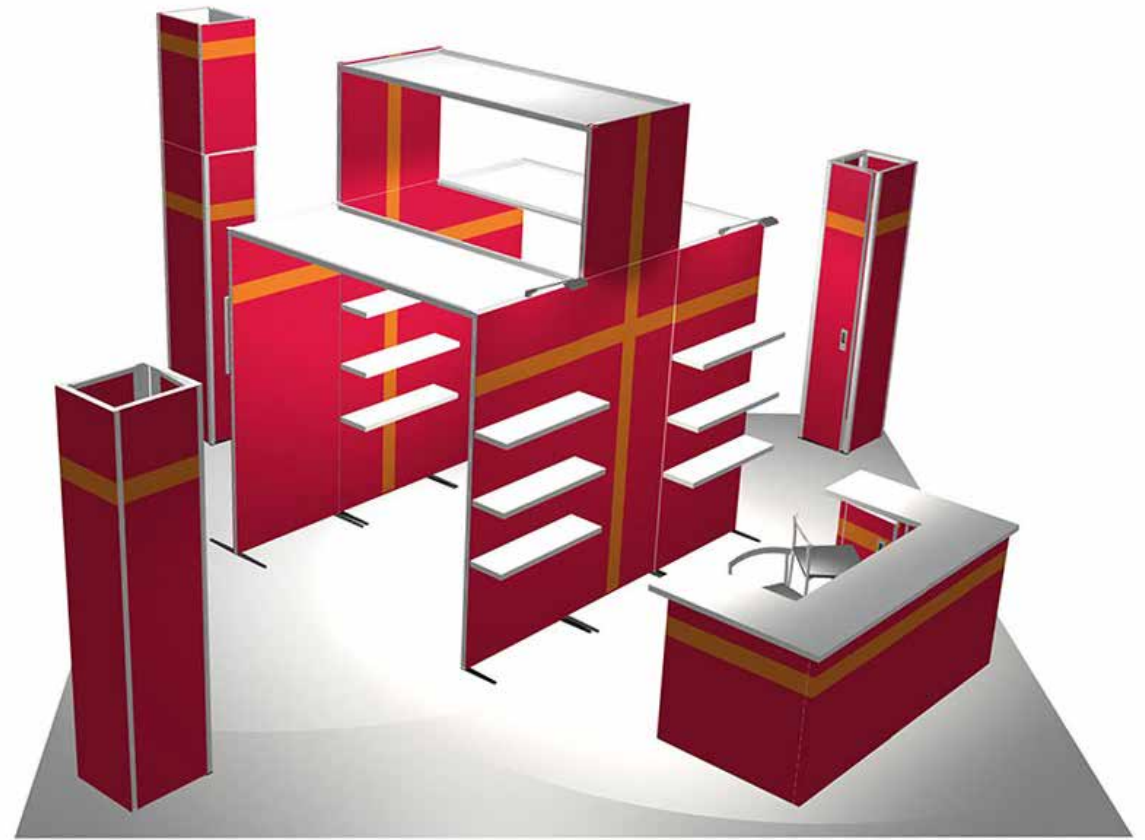
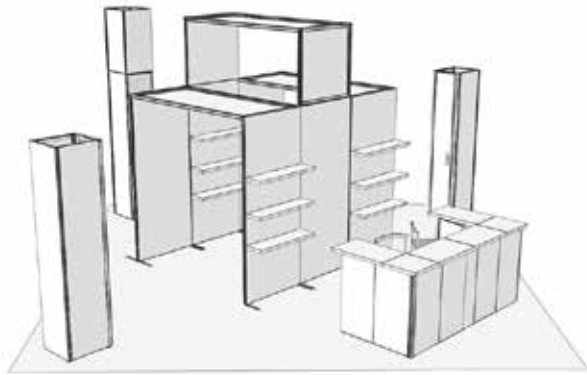

- 114" w x 85.5" d x 131" h structure with shelf arch module, storage & graphic

- 1 wood crate (horizontal or vertical available)

**Optional:**

- 27.5" x 39.5" x 17.3" small counter w/door

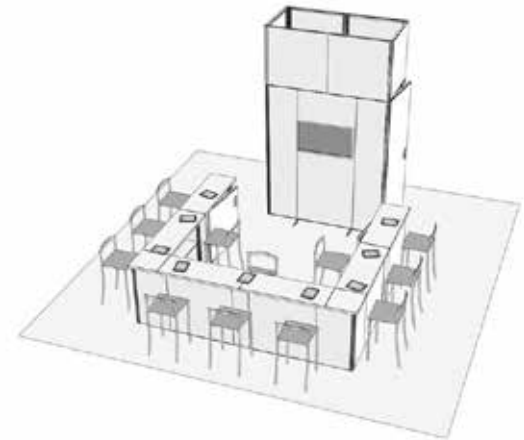

- 76" w x 38" d x 131" h structure with multi media module, storage & graphic
- 1 wood crate (horizontal or vertical available)

**Optional:**

- 27.5" x 39.5" x 17.3" small counter w/door

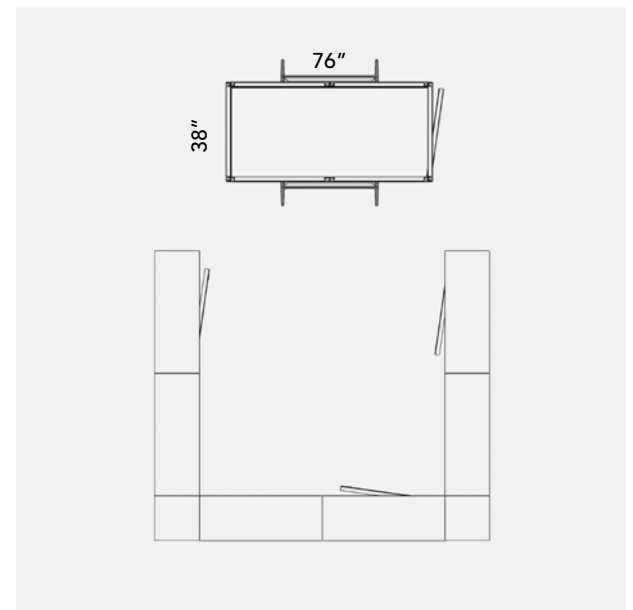



H-Line Modular 10ft x 20ft h20-01



228"

114"

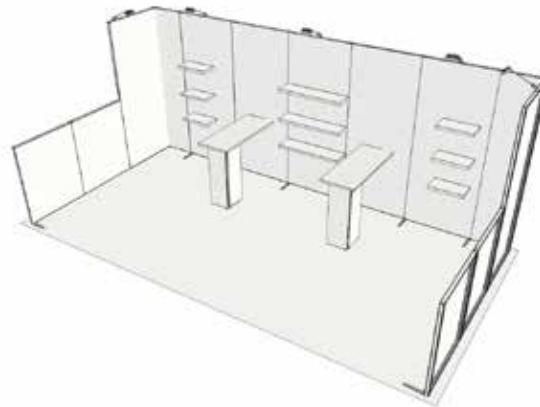
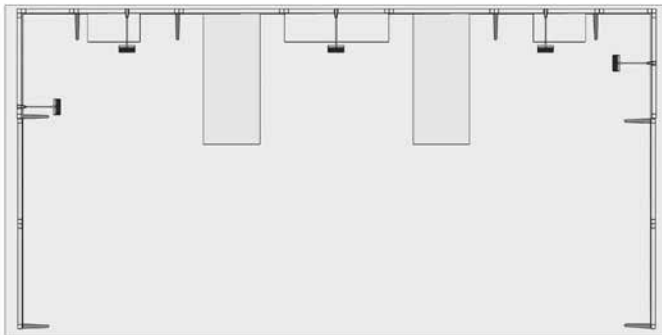

- 228"w x 114"d x 93"h structure with half height, shelves & console module & graphic
- 5 LED lights
- 1 wood crate (horizontal or vertical available)

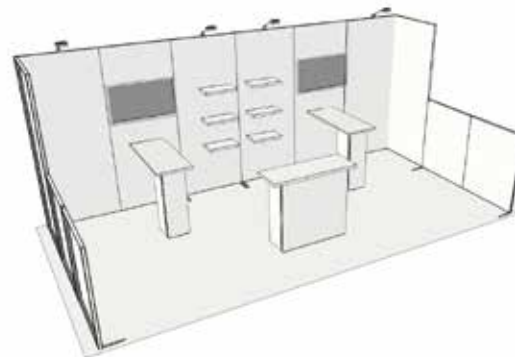
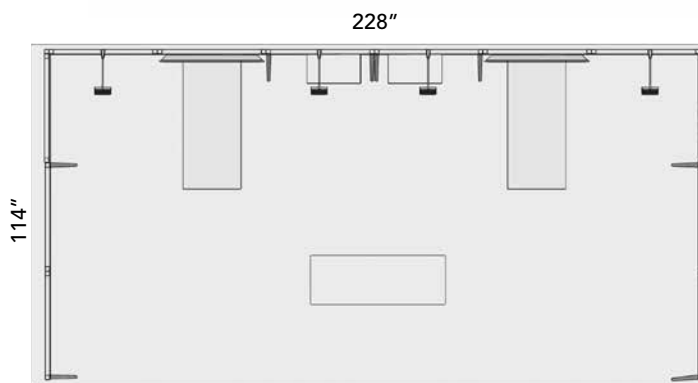
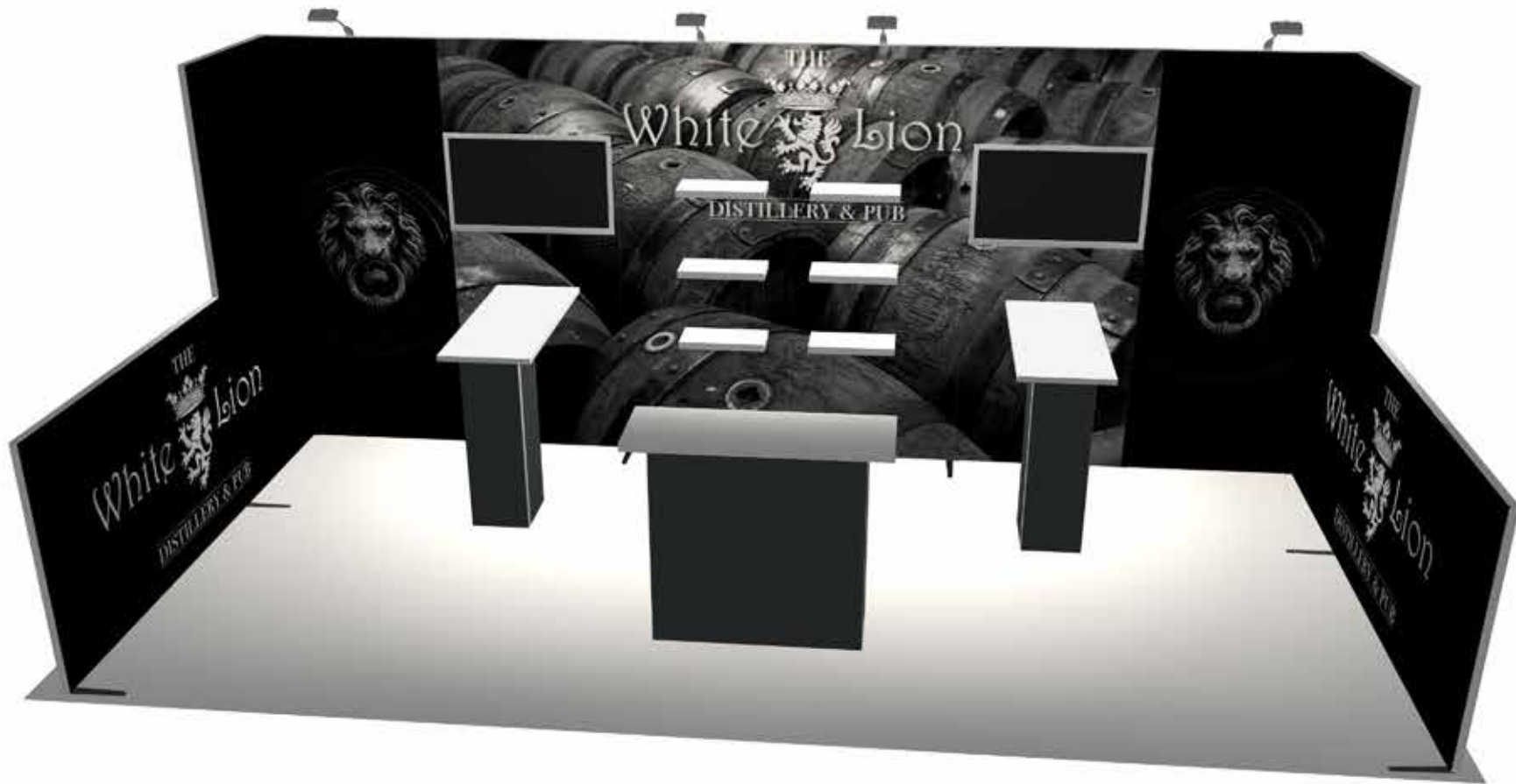

- 228" w x 114" d x 93" h structure with half height, shelf & console modules & graphic

- 4 LED lights

- 1 wood crate (horizontal or vertical available)

**Optional:**

- 47.25" x 39.5" x 17.3" medium counter

# H-Line Modular 10ft x 20ft h20-03



230"

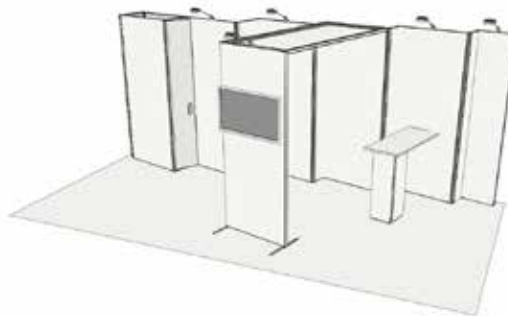
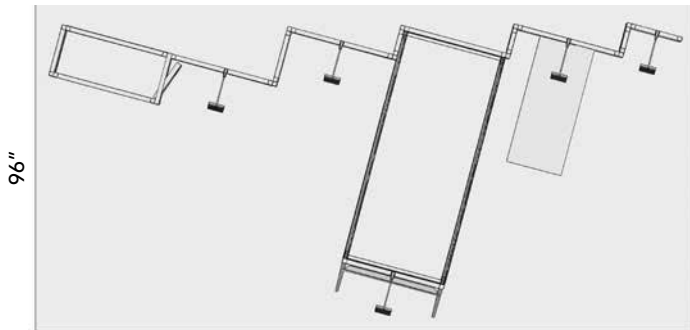

- 230" w x 96" d x 93" h structure with arch & console module & graphic
- 5 LED lights
- 1 wood crate (horizontal or vertical available)



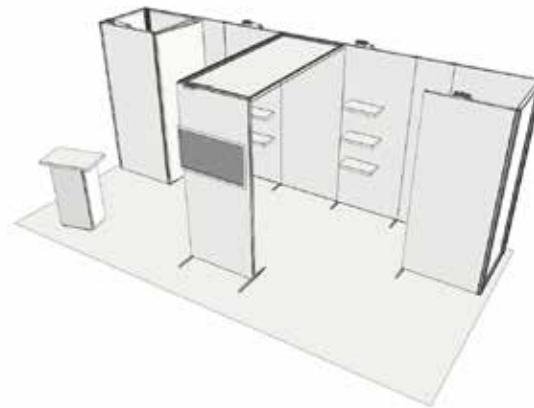
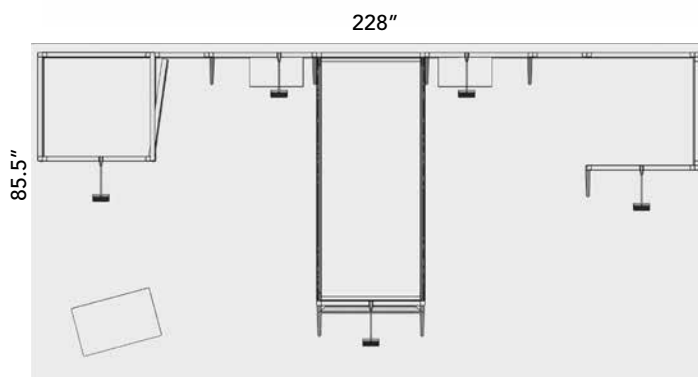

- 228" w x 85.5" d x 93" h structure with multi media arch module, storage & graphic

- 5 LED lights

- 1 wood crate (horizontal or vertical available)

**Optional:**

- 27.5" x 39.5" x 17.3" small counter w/door

# H-Line Modular 10ft x 20ft h20-05



228"

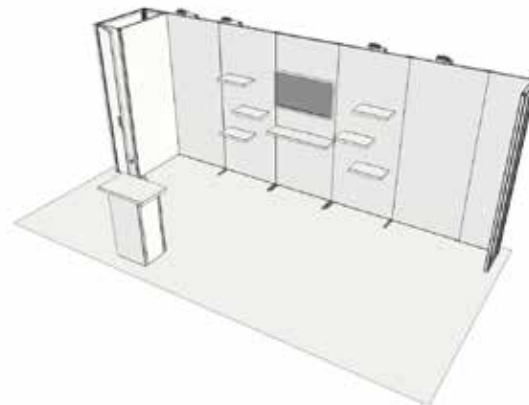
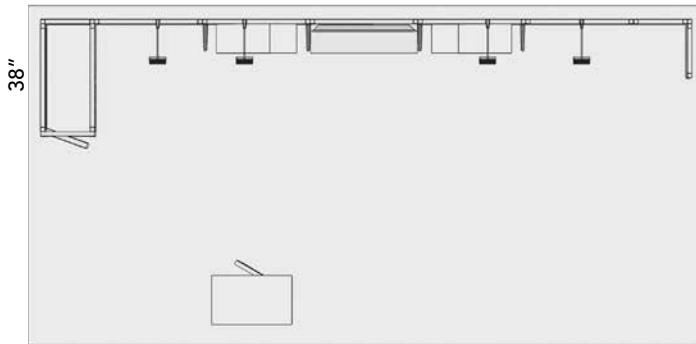

- 228" w x 38" d x 93" h structure with multi media modules, shelf modules, closet & graphic
  - 4 LED lights
  - 1 wood crate (horizontal or vertical available)
- Optional:**
- 27.5" x 39.5" x 17.3" small counter

H-Line Modular 10ft x 20ft h20-06



228"

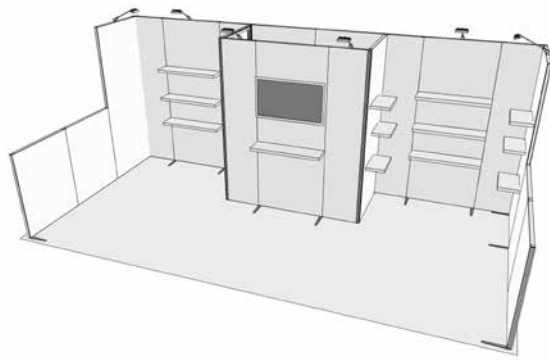
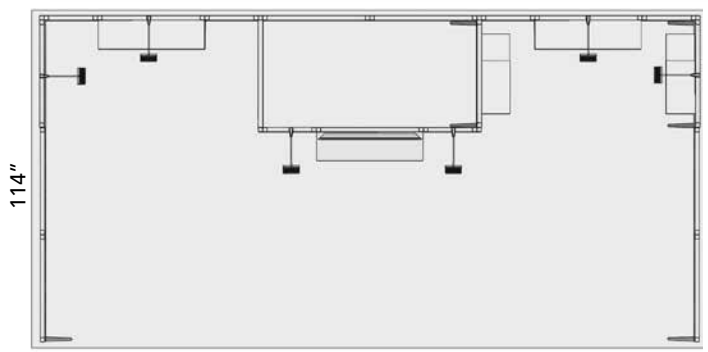

- 228" w x 114" d x 93" h structure with multi media module, shelf module, storage & graphic
- 6 LED lights
- 1 wood crate (horizontal or vertical available)



# H-Line Modular 10ft x 20ft h20-07

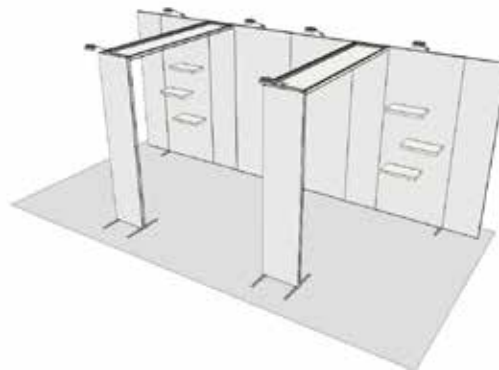
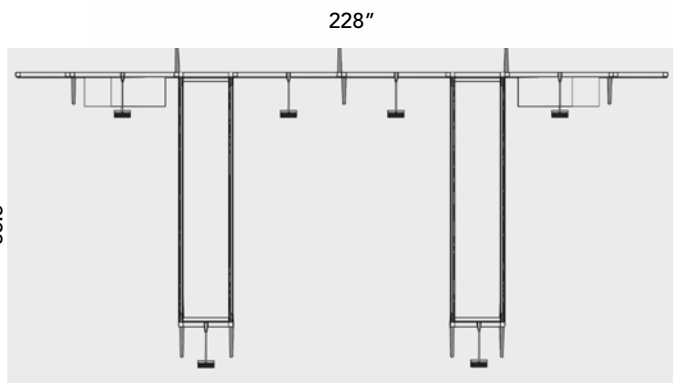

- 228" w x 85.5" d x 93" h structure with shelf and arch modules & graphic
- 5 LED lights
- 1 wood crate (horizontal or vertical available)

## H-Line Modular Lightbox



228"

19"

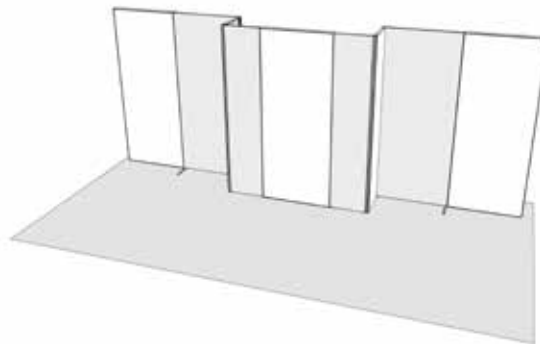
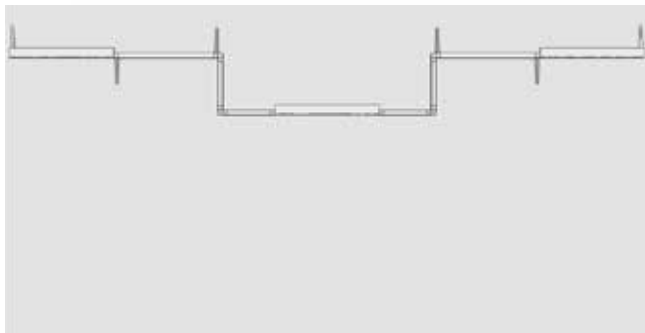

- 228" w x 19" d x 93" h structure with lightboxes & graphic
- 1 wood crate (horizontal or vertical available)

# H-Line Modular Counters

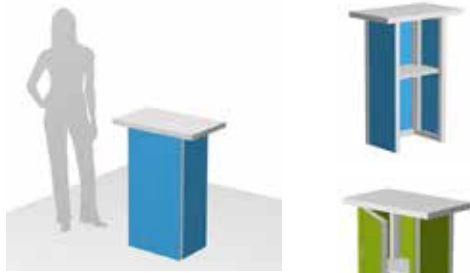

## Small counter with or w/o door

1 Shelf inside

### Size:

Base - 39.5" h X 19" w X 13.4" d  
 Counter top - 27.5" w X 17.3" d  
 Foot print - 27.5" w X 17.3" d

### Weight:

Counter only - **40lbs**  
 Counter & shipping case w/wheels  
 (Case size 24"x48"x9") - **70lbs**

### Weight with door:

Counter only - **56lbs**  
 Counter & shipping case w/wheels  
 (Case size 24"x48"x9") - **86lbs**

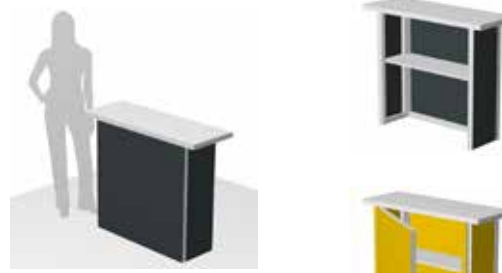

## Medium counter with or w/o door

1 Shelf inside

### Size:

Base - 39.5" h X 38" w X 13.4" d  
 Counter top - 47.25" w X 17.3" d  
 Foot print - 47.25" w X 17.3" d

### Weight:

Counter only - **51lbs**  
 Counter ships with display in display crate.

### Weight with door:

Counter only - **76lbs**  
 Counter ships with display in display crate.

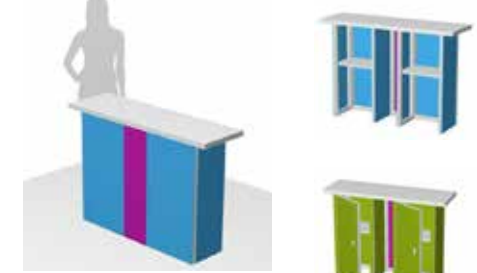

## Large counter with or w/o door

1 Shelf inside each counter - 2 total.

### Size:

Base - 39.5" h X 47.5" w X 13.4" d  
 Counter top - 64.5" w X 17.3" d  
 Foot print - 64.5" w X 17.3" d

### Weight:

Counter only - **90lbs**  
 Counter & 2 shipping cases w/wheels  
 (Each case size 24"x48"x9") - **120lbs.**

### Weight with doors:

Counter only - **120lbs**  
 Counter & 2 shipping cases  
 (Each case size 24"x48"x9") - **180lbs.**

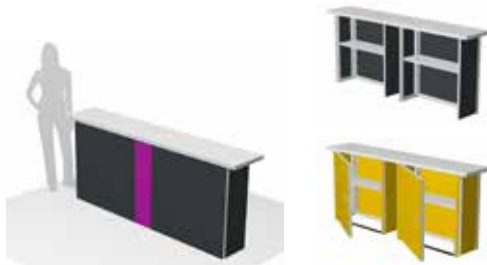

## X-Large counter with or w/o door

1 Shelf inside each counter - 2 total.

### Size:

Base - 39.5" h X 85.5" w X 13.4" d  
 Counter top - 104" w X 17.3" d  
 Foot print - 104" w X 17.3" d

### Weight:

Counter only - **110lbs**  
 Counter ships with display in display crate.

### Weight with doors:

Counter only - **160lbs**  
 Counter ships with display in display crate.

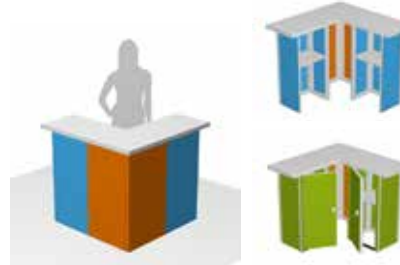

## Large corner counter with or w/o door

1 Shelf inside each counter - 2 total.

### Size:

Base - 39.5" h X 38" w X 38" d  
 Counter top - 55" w X 55" d  
 Foot print - 78" w X 67" d

### Weight:

Counter only - **100lbs**  
 Counter & 2 shipping cases  
 (Each case size 24"x48"x9") - **160lbs.**

### Weight with doors:

Counter only - **135lbs**  
 Counter & 2 shipping cases  
 (Each case size 24"x48"x9") - **195lbs.**

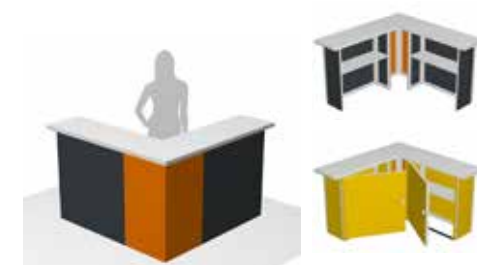

## X-Large corner counter with or w/o door

1 Shelf inside each counter - 2 total.

### Size:

Base - 39.5" h X 76" w X 76" d  
 Counter top - 95" w X 95" d  
 Foot print - 134" w X 116" d

### Weight:

Counter only - **125lbs**  
 Counter ships with display in display crate.

### Weight with doors:

Counter only - **175lbs**  
 Counter ships with display in display crate.

Create exciting and functional counters by combining multiple modules.

## H-Line Modular Counters

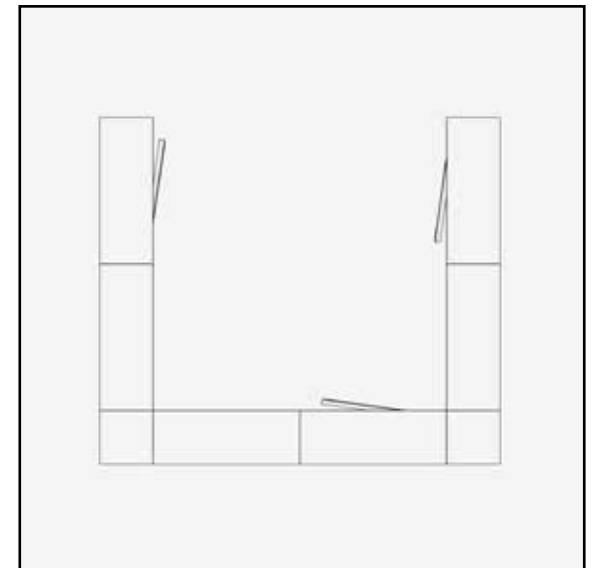
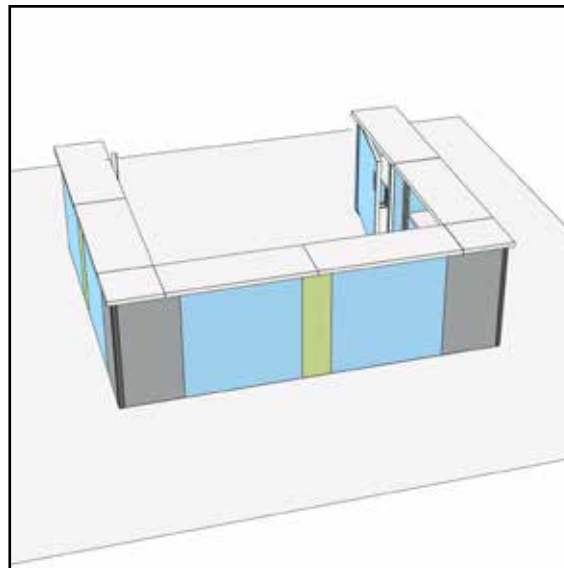
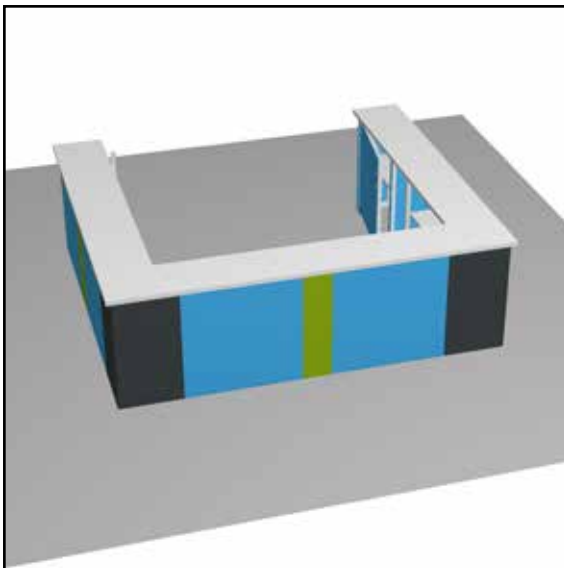
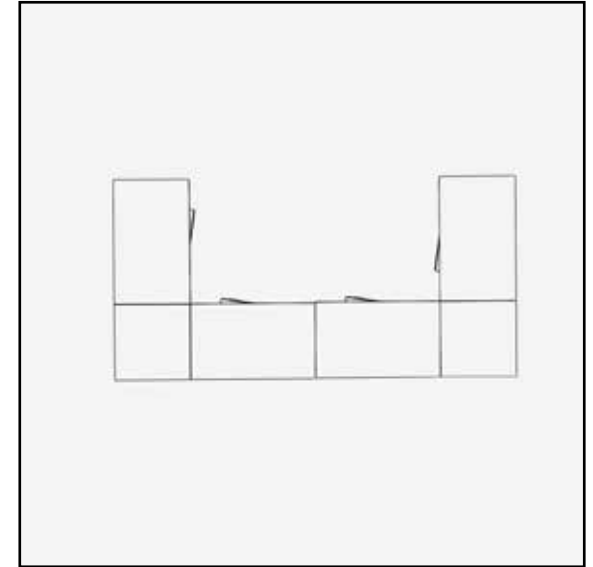
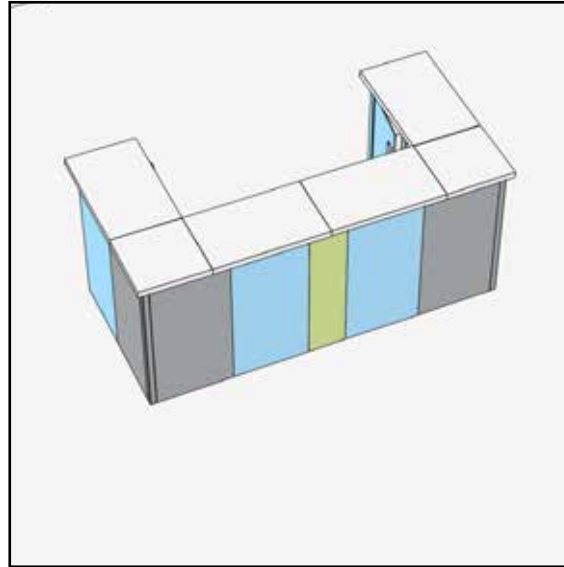
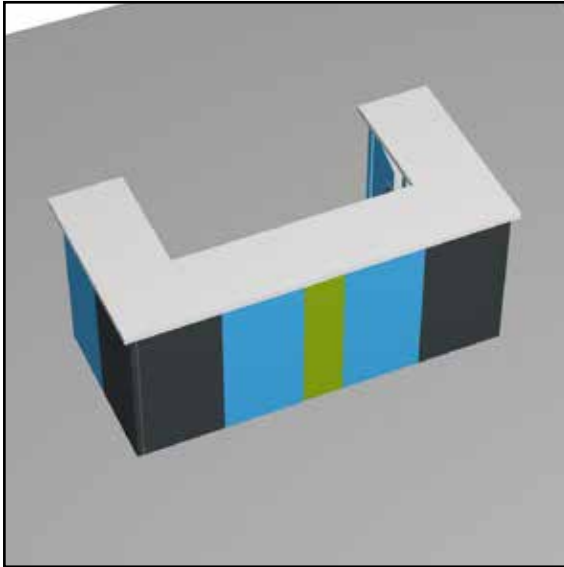



# Crates & Accessories



Frames ship with graphics pre-installed.



Horizontal Crate

Holds:  
 14 modules size - 38" x 93"  
 1 module size - 9.5" x 93"



Vertical Crate

Holds:  
 10 modules size - 38" x 93"  
 2 doors size - 38" x 93"  
 1 canopy size - 38" x 85.5"  
 4 - 38" counter frames  
 1 - 38" counter door

NOTE: Check with your shipping company about restrictions or prior notice requirements on crates.

h-line

MODULAR DISPLAYS

**FEATURING PRE-INSTALLED  
ONYX FABRIC GRAPHICS**

**EDITION TWO 11.11.16**

All info is correct at time of publishing, manufactures changes may occur.